

Evolve™

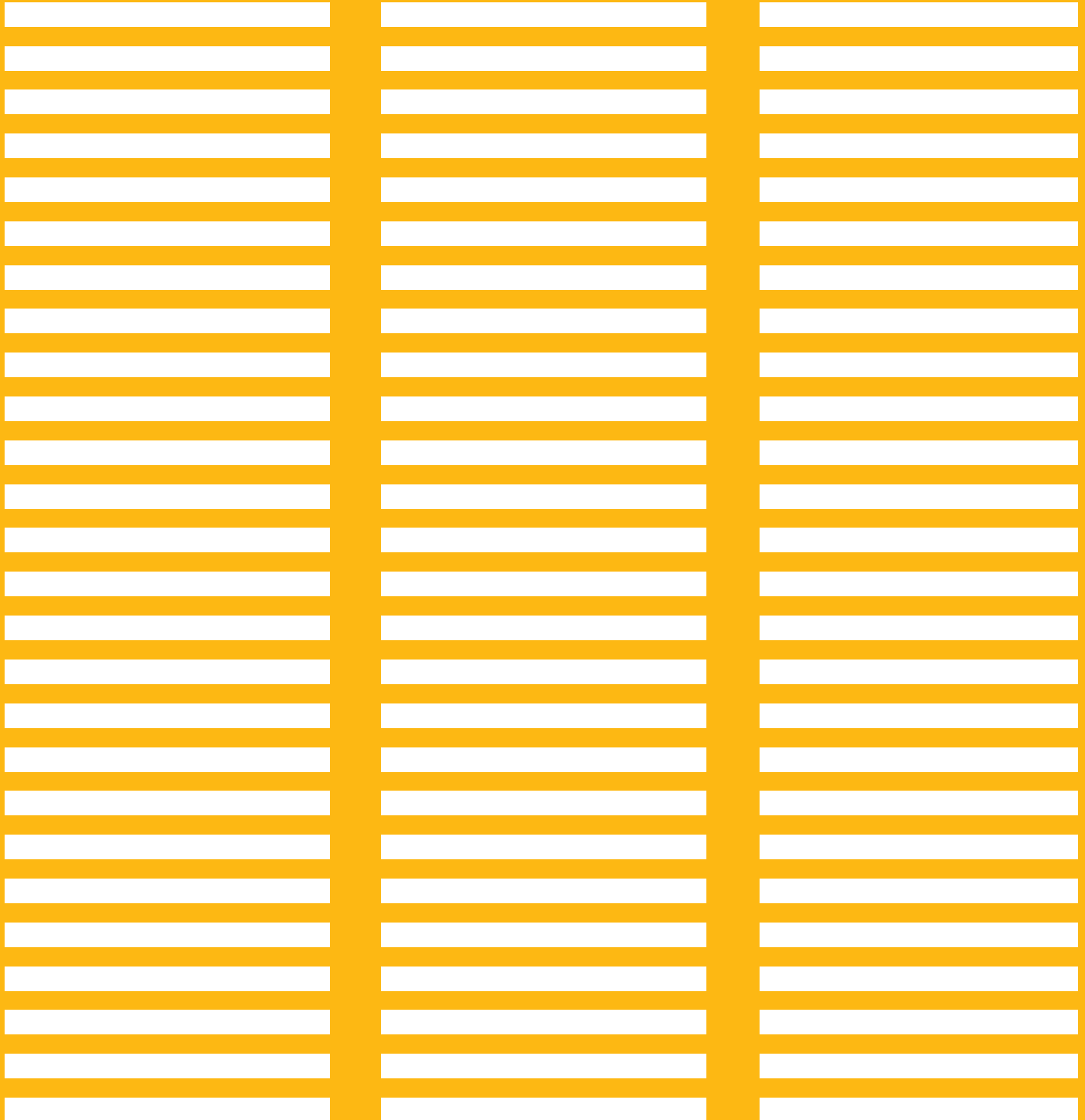

Evoke is a luxurious seating system specifically designed for conference, convention and educational facilities.

The fully upholstered seat and backrest cushions are ergonomically contoured molded polyurethane, providing exceptional long term seating comfort. The backrest can be fixed, or articulated using a gas-spring for additional access along rows. Evoke is complemented with the JOT writing tablet, providing an A3 writing surface in vandal-proof phenolic laminate, with a gas assisted anti-panic deployment feature. Evoke and JOT offer all the solutions required in today's modern multi-purpose facilities.

Molded polyurethane foam

The specifically formulated polyurethane foam used to individually mold seats and backrest cushions provides the proper balance between support and comfort. The inherent quality of the process ensures the foam will not collapse or flatten out at any stage but provide lasting comfort and ergonomic support.

Gravity tilt seats

Gravity-tilt seats, using fully enclosed counterweights are silent, dependable and reliable – a sensible alternative to high maintenance and unreliable pivot springs.

Gas articulated backrest (Evoke Compact)

An optional articulated backrest option provides improved egress and/or access along seating rows. When the seat component is lowered the backrest is reclined through a concealed linking bar whilst motion is controlled by a dampened gas-spring silent in operation.

Removable covers/laminated fabric's

All Evoke covers are zip removable for ease of replacement and feature foam backed fabric for stretch control and elimination of seam slippage and sagging.

Mounting system

Evoke beam mounting system enables fixing bracket positioning at infinite locations along a row, eliminating loss of seating locations due to expansion joints, angle changes or step interference.

Easy installation

Once beam system is installed, seats delivered to site fully assembled are quickly and easily located into position, and locked by the rotation of two vandal-proof toggles. JOT tablet is also delivered fully assembled and has a single vandal-proof locking toggle.

Removable units

Single and two seat removable units come standard with Camatic's patented floor locking system, requiring no tools or fixing components for use. When the free standing units are located into position a magnet in the foot attracts the pop-up anchor, while a simple latch ensures the unit remains in position.

Trolleys holding up to 12 seats single level or 24 seats on two levels are available.

Use of recycled plastics

In an effort to minimize the effect on the environment, recycled plastics are used in the molding of non structural components. All plastic components bear the recycling code identification marking, compliant with worldwide recycling standards.

Evoke Features

	Evoke	Compact	Removable
Beam mounting provides for future upgrades and/or reconfiguration	•	•	•
Tread or riser mounting	•	•	
Free standing with optional magnetic lock down system			•
Ergonomic profile offers enduring comfort	•	•	•
Individually molded polyurethane seat and backrest cushions	•	•	•
Zip removable seat and backrest covers	•	•	•
Gravity tilt seat – silent and reliable, with zero maintenance	•	•	•
Integral skin polyurethane armrest pad	•	•	•
Upholstered side panels to box style arm	•	•	•
JOT A3 writing tablet – vandal-proof surface with anti-panic mechanism	•	•	•
Quickly installed with beam and toggle locking system	•	•	•
Designed to exceed requirements of ASTM & En12727 standards	•	•	•

Options

Seat numbers	•	•	•
Row end ID plates	•	•	•
Aisle lighting [LED]	•	•	
Seat sponsor name plate	•	•	•
Backrest outer veneer	•	•	•
Seat outer veneer	•	•	•
Power outlet to armrest [RH]	•	•	•
JOT A3 writing tablet – open style (no side panels)	•	•	•
JOT A3 writing tablet – open style with nylon arm pad	•	•	•
Writing tablet [vandal-proof surface with anti-panic deployment]	•	•	•
Removable system – 1 & 2 seat units			•

Evoked

This fixed back chair with gravity tilting seat has an ergonomic relationship that provides the perfect balance between form and function. Evoke is a fully upholstered luxurious chair that provides patrons with exceptional comfort, while functional operation of the writing tablet system exceeds all ergonomic criteria. A sophisticated fully enclosed mechanism returns the writing tablet automatically to its home position when the user stands (Anti-panic).

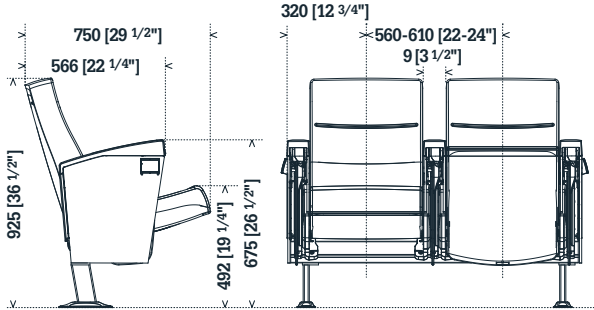

Evoked Compact

Evoked Compact is used when row spacing is tight or improved egress is required. A gas-spring mechanism reclines the back to its optimal position when the seat is deployed, and returns the chair to a compact size when it is unoccupied. When occupied the chair has the identical proportions and ergonomic contouring of the standard Evoke chair.

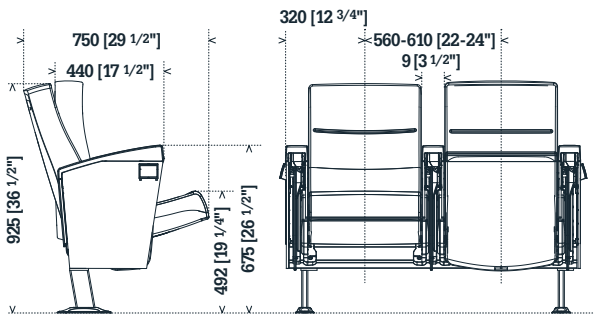

Evoked Removable

Evoked Removable makes reconfiguration of seating simple. The freestanding units are safe to use when not permanently fixed to the floor, however are easy to locate and fix into position. A patented locking system utilizes a magnet to pull the fixing post up from the floor, whilst a simple latch locks the unit in position. Rear wheels on the freestanding legs make it easy for one person to load the seats onto the trolleys for relocation. Evoked Removable can be configured to any venues requirements.

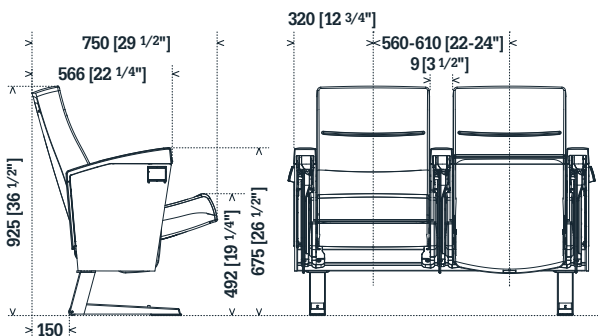

Australia

Head Office & Manufacturing
Camatic Pty Ltd
93 Lewis Road
Wantirna South
Victoria 3152 Australia
Telephone: 61 3 9837 7777
Facsimile: 61 3 9837 7700
Email: sales@camatic.com
www.camatic.com

USA

Camatic Seating Inc
1010 West Eules Blvd
Suite 110, Eules
TX 76040 USA
Telephone: 1 682 503 5317
Facsimile: 1 817 633 2190

CAMATIC

Representation

Australasia
South East Asia
North America
Europe
Middle East
CIS

Camatic Seating is committed to helping the environment and uses recycled materials on non-structural components. Camatic Seating reserves the right to vary specifications without notice. All dimensions are nominal and should be confirmed with Camatic Seating.